

# DYNACO MK3 Autobias upgrade manual

## Preparation

- We disconnect the wires and disassemble the original PCB driver.
- Disconnect the connecting wire at socket 1,8 between tubes V3 and V4. Pins 1-8 on sockets V3 and V4 remain connected.
- We disconnect the 11.2 Ohm resistor according to the picture.
- We disconnect the wire from pin 4 of the V3 socket, which originally led to the driver. The wire to the OT remains connected.
- We disconnect the wire from the slider of the BIAS potentiometer leading to the driver.

## Construction

- We mount the board with the new driver.
- We connect the ground point to terminal 3 of the combined capacitor.
- We connect the input to the IN terminal on the driver.
- We connect the heating tubes terminals on the driver board and connect tube V4 to pins 2 and 7.
- We connect the feedback wire (680 Ohm on the terminal block) to the NF A terminal.
- Connect the Rg V4 terminal to pin 6 of the V4 tube socket.
- Connect the Rg V3 terminal to pin 6 of the V3 tube socket.
- We connect the wire between the driver terminal B+ and output 4 of the combined capacitor.

## Connecting the autobias module

- We connect the terminals 6.3V to 12.6V AC in AB to the heating tubes 6.3V in amp.
- Terminal in AB - V3 CATH připojíme ke kolíkům 1 a 8 tube V3.
- Terminal in AB - V4 CATH připojíme ke kolíkům 1 a 8 tube V4.
- Connect the terminal in AB - V3 GRD to the terminal ABQ-GRD V3 on the driver board.
- Connect the terminal in AB - V4 GRD to the terminal ABQ-GRD V4 on the driver board.
- We connect the GND AB terminal to GND the driver terminal as shown in the picture.
- We connect the BIAS AB terminal to ABQ-BIAS the driver terminal as shown in the picture.

## Settings

- PP stage 2 x EL34, class AB1, ultralinear:  
set bias for EL34 tube. The recommended anode current in the AB1 class is 42.5 mA.  $42.5 = 425 / 10$ . We therefore set  $U_{ref} = 425 \text{ mV}$  (0.425 V). Trimpot in AB.

## Very important!

- The heating circuit for supplying the **AB-D** module 6.3V AC must **not be connected** to the ground!
- The heating circuit for supplying the **AB-Di** 6.3 V AC module **can be connected** to ground!
- DO NOT EVER readjust the trimmer once the AB-Q module is installed and wired up. The whole idea is to set in ONCE and forget!

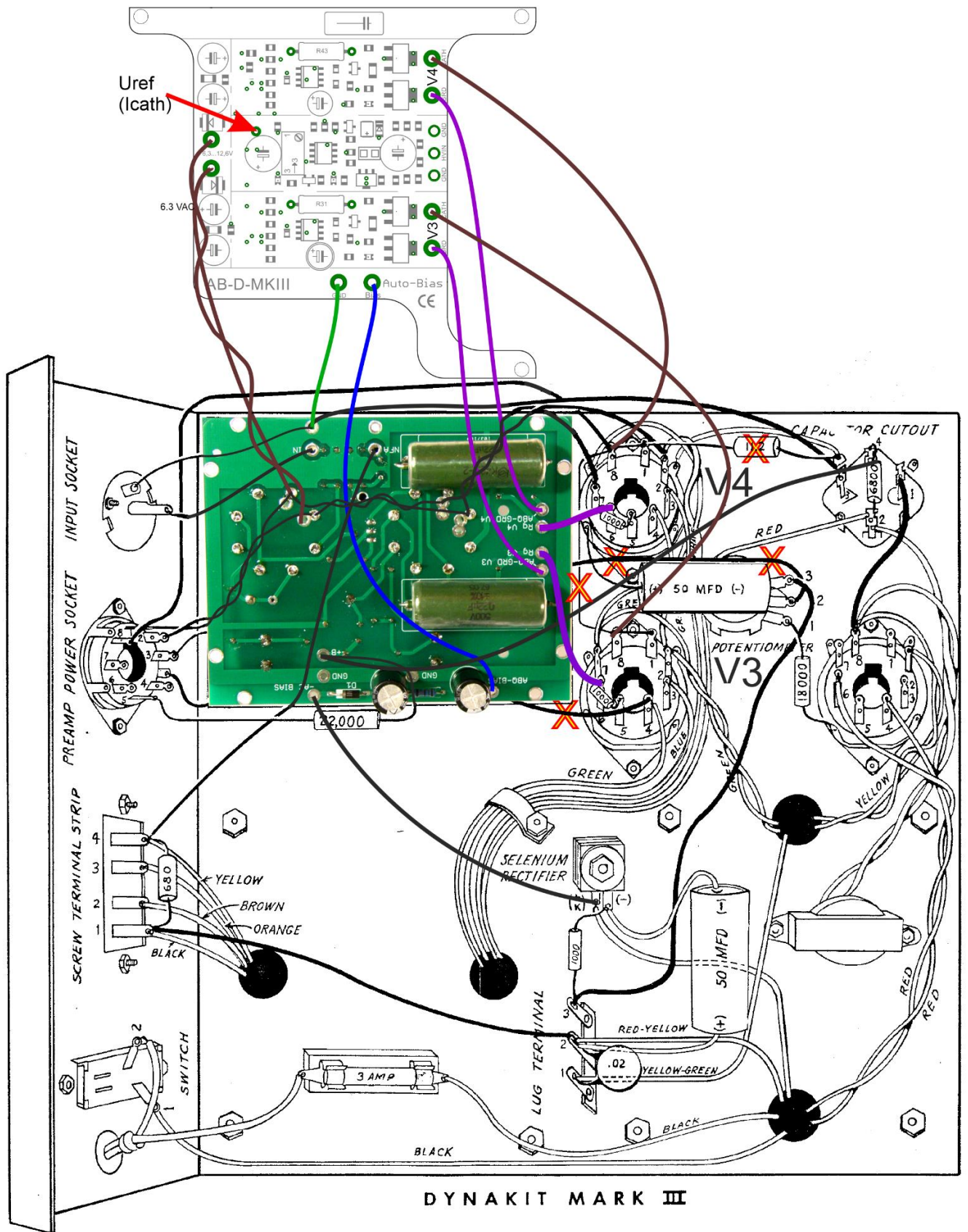

Assembly diagram AB-D-MK III

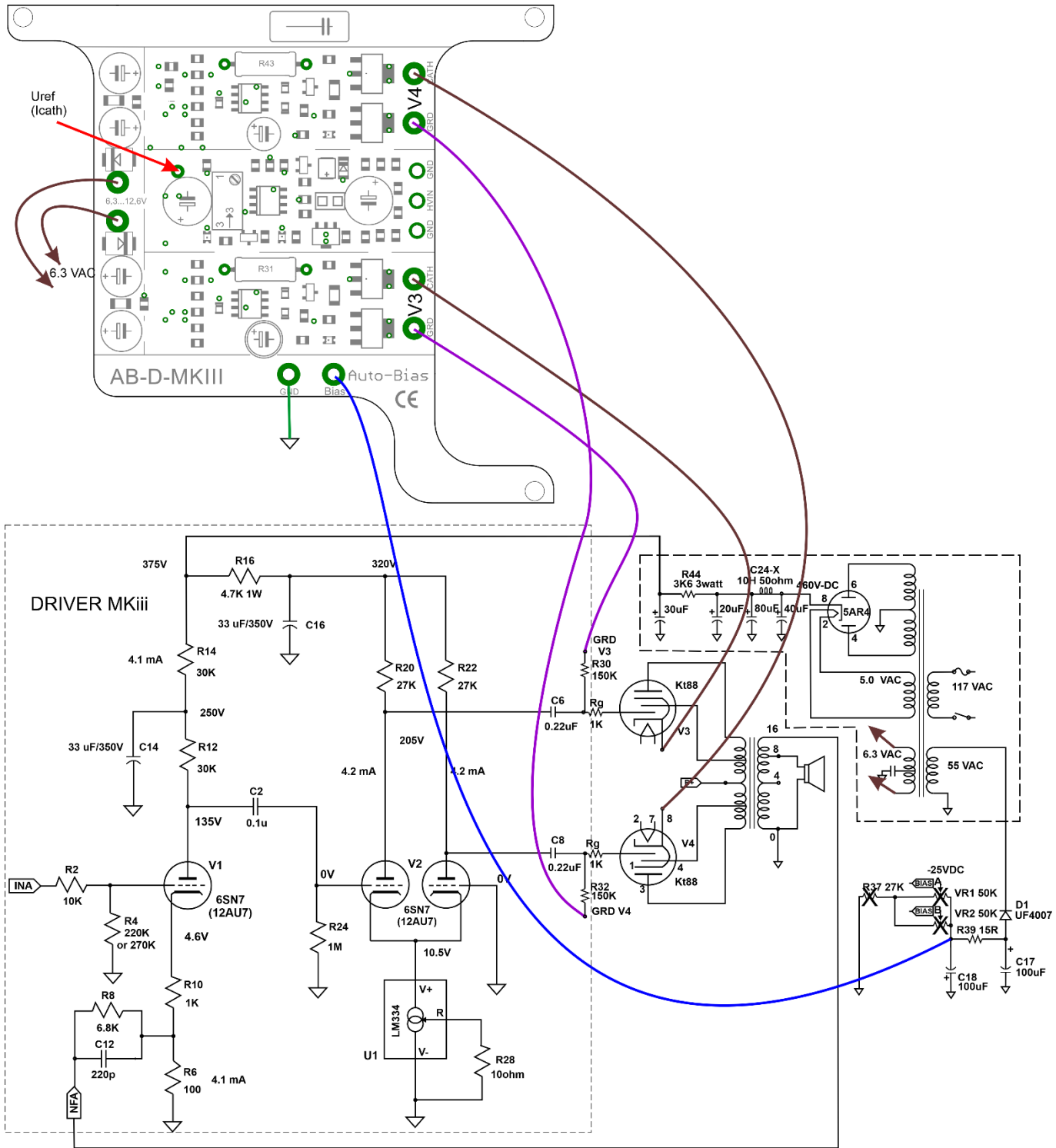

Wiring diagram AB-D-MK III

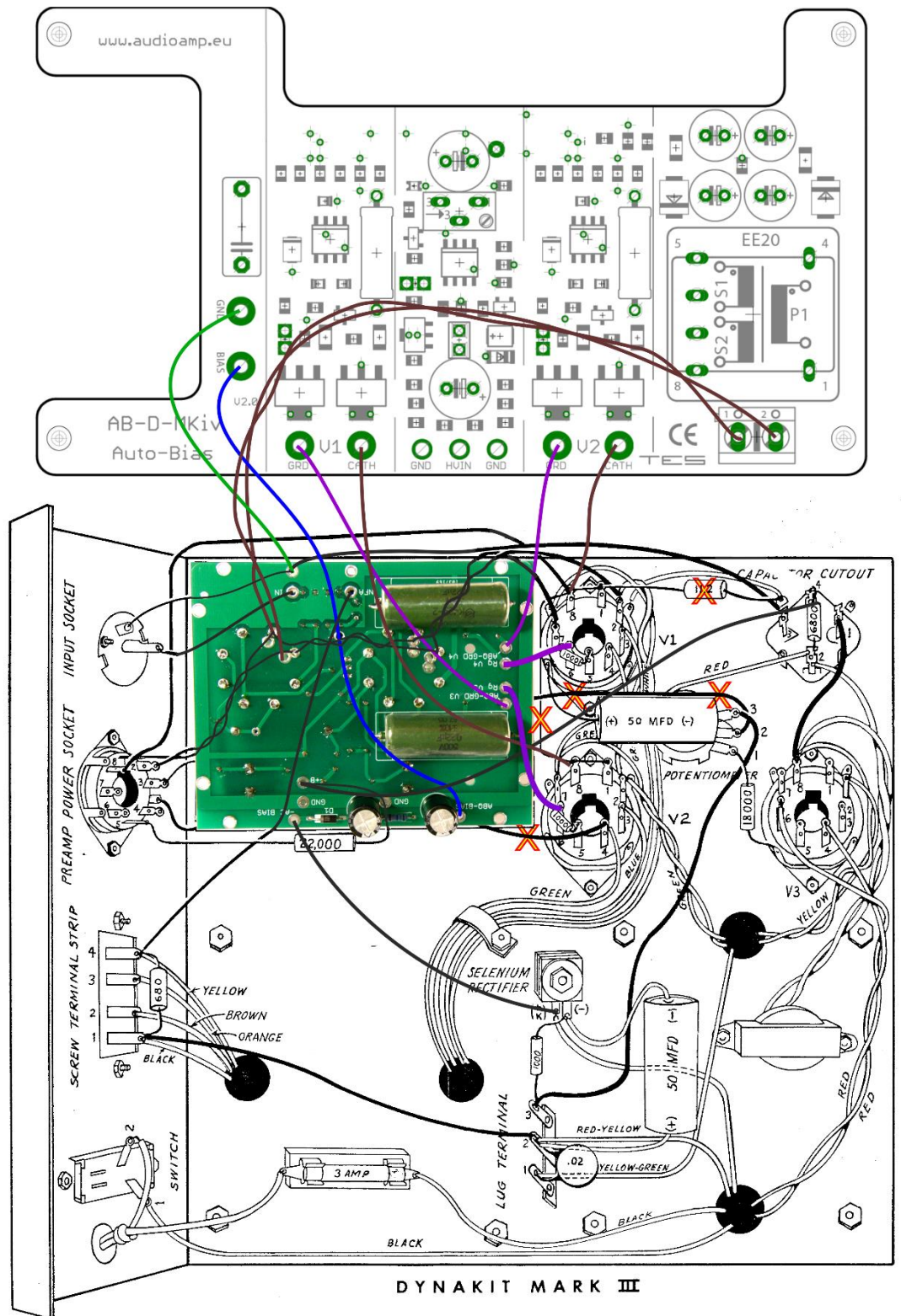

Assembly diagram AB-Di-MK III

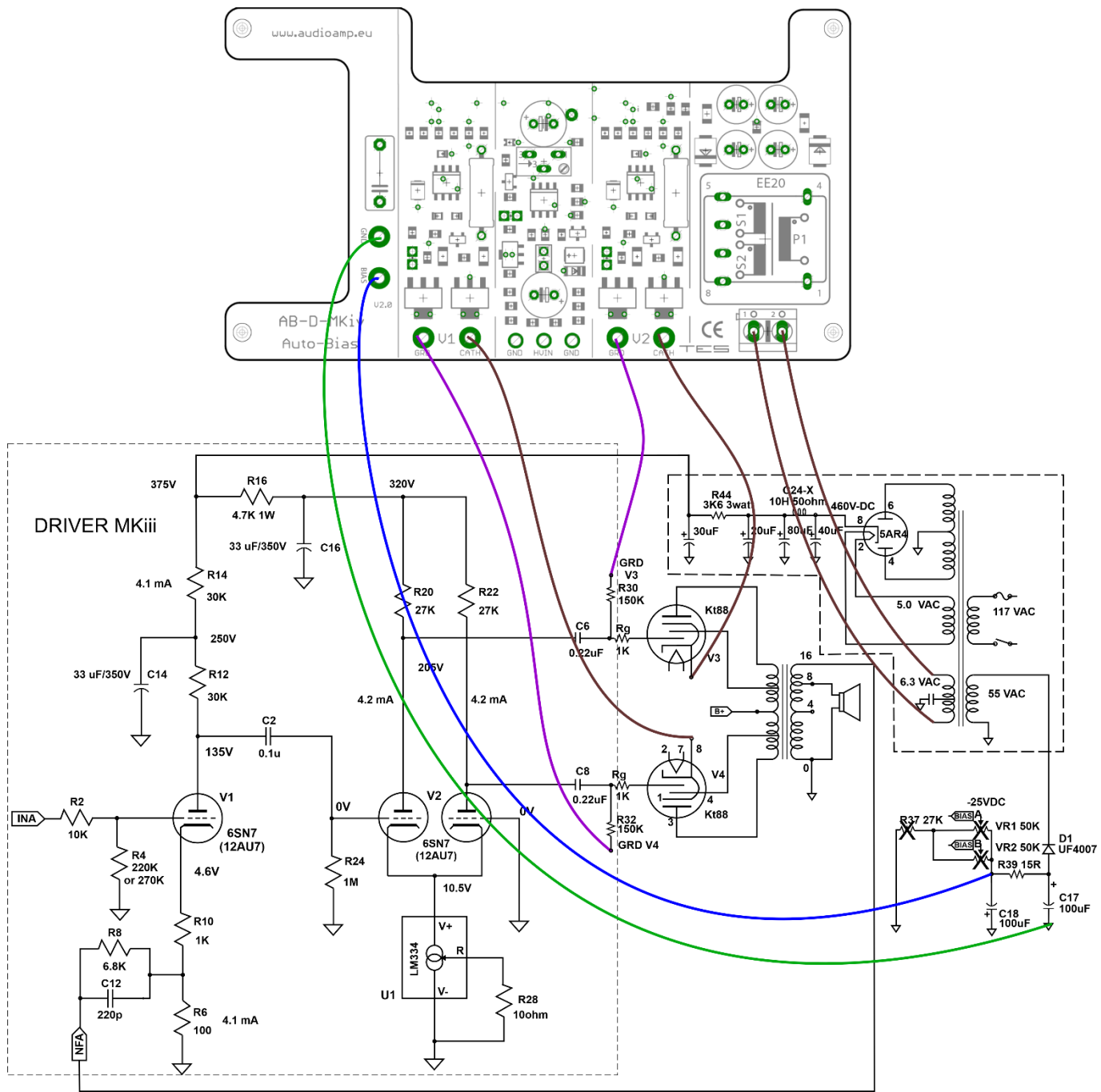

Wiring diagram AB-Di-MK III

